



Главная

Семейство продуктов	Zelio Logic
Тип изделия или компонента	Модем GSM
Состав комплекта	1 антенна с кабелем 1 кабель питания 2 монтажных ушка для крепления к панели Крепление на DIN рейке (в сборе с GSM модемом) Модем GSM
Тип модема	Типовой 4-диап. 900/1800 МГц, 850/1900 МГц
Доступные функции	Контроль обновления микропрограммного обеспечения Отправка аварийного сигнала/получение инструкции Отправка аварийного сигнала по электронному адресу Перенос программы
Резервируемые данные	Флеш-память
[Us] номинальное напряжение питания	12...24 V пост. ток

Дополнительно

Кол-во сообщений	≤ 28
Сохраняемые данные	Дата и время Дискретное и цифровое значение По телефону/e-mail
Пределы напряжения питания	5,5...32 V
Потребляемый ток	87 A 24 V 165 mA 12 V ≤ 2100 mA 5,5 V
Рассеиваемая мощность, Вт	2,1 W
Соответствующий номинал предохранителя	2,5 A
Электрическое соединение	1 антенна с кабелем 1 кабель 1 кабель Com-M Com-M специализированный для Zelio последовательный RS232 , специальный коммуникационный протокол Zelio для связь с модемом, команды TA 1 кабель Com-Z Com-Z специализированный для Zelio , специальный коммуникационный протокол Zelio для интеллектуальные реле Zelio Logic SR.B..... и SR2 E..... версия (≥ V3.1) Кабель питания
Длина кабеля	1,5 m кабель питания 2,5 m антенна с кабелем
Изоляция	1780 В оптопара , тип разъема: Com-Z специализированный для Zelio Кабелем R2 CBL07 , тип разъема: Com-M специализированный для Zelio
Тип подключения	Винтовые зажимы , 1 x 0,25...1 x 2,5 мм ² , 24...14 , гибкий кабели с кабельным наконечником Винтовые зажимы , 2 x 0,25...2 x 1,5 мм ² , 23...16 , сплошной кабели Винтовые зажимы , 1 x 0,25...1 x 2,5 мм ² , 24...14 , полутвердый кабели Винтовые зажимы , 1 x 0,25...1 x 2,5 мм ² , 24...14 , сплошной кабели Винтовые зажимы , 2 x 0,25...2 x 0,75 мм ² , 24...18 , гибкий кабели с кабельным наконечником
Момент затяжки	0,5 N.m
Масса продукта	0,335 kg

Окружающая среда

Сертификаты продуктов	C-Tick CSA FCC часть 15 стандарт GOST IC PTCRB UL
Стандарты	EN/IEC 60068-2-32 EN/IEC 60068-2-6 Fc
Электромагнитная совместимость	Испытание на невосприимчивость к коммутационным помехам/коротким пакетам уровень 1 EN/IEC 61000-4-4 Испытание стойкости к с электролитическому разряду уровень 2 контакт EN/IEC 61000-4-2 Испытание стойкости к с электролитическому разряду уровень 3 воздух EN/IEC 61000-4-2 Испытание стойкости к электромагнитному полю EN/IEC 61000-4-3 Проверка стойкости к наведенным РЧ помехам уровень 2 EN/IEC 61000-4-6
Степень защиты IP	IP31 соответствует требованиям IEC 60529
Характеристики окружающей среды	Директива R & TTE соответствует требованиям ETSI EN 301419-1 Директива R & TTE соответствует требованиям ETSI EN 301489-7 Директива R & TTE соответствует требованиям ETSI EN 301511 Директива по ЭМС соответствует требованиям EN 301489-1 Директива по низковольтному оборудованию соответствует требованиям EN/IEC 60950-1
Помеха излучаемая/наведенная	Класс В соответствует требованиям EN 55022-11 группа 1
Степень загрязнения	2 соответствует требованиям EN/IEC 61131-2
Температура окружающей среды при работе	-20...55 °C соответствует требованиям МЭК 60068-2-1 и МЭК 60068-2-2
Температура окружающей среды при хранении	-40...70 °C
Рабочая высота	2000 m
Максимальная высота при транспортировке	≤ 3048 m
Относительная влажность	95 % при 55 °C без образования конденсата 95 % без образования конденсата во время хранения
Дата европейского сертификата соответствия RoHS	4Q2009
Состояние европейского сертификата RoHS	Будет соответствовать

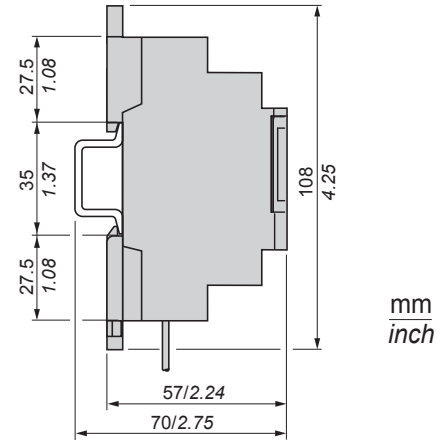
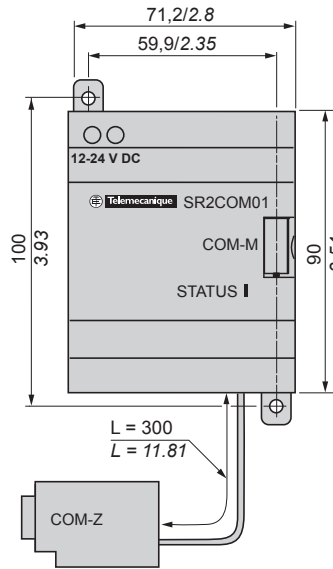
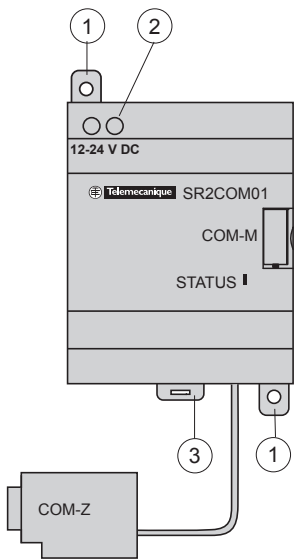

SR2MAN01EN
SR2MAN01FR
SR2MAN01DE
SR2MAN01SP
SR2MAN01IT
SR2MAN01PO



CDROM
SR2 SFT01

- 1 - Retractable mounting feet / Pattes de fixations retractables / Einziehbare Befestigungslaschen / Patas de fijaciones retractables / Asole estraibili di fissaggio / Patilhas de fixação retrácteis
- 2 - Power supply terminals / Borniers à vis d'alimentation / Schraubklemmen für die Anschlussspannung / Terminales de tornillos de alimentación / Morsettiera di alimentazione / Terminais de parafusos alimentação
- 3 - 35 mm rail clip-in spring / Ressort de clipsage sur rail de 35 mm / Klemmfeder auf 35 mm Schiene / Resorte de clipsado en carril 35 mm / Molla di aggancio su barra metallica da 35 mm / Mola de engate sobre carril de 35 mm

IMPORTANT : This document provides installation instructions only. Refer to User Manual #SR2MAN01EN for complete Zelio 2 set-up, operation and software instructions. Those responsible for the application, implementation or use of this product must ensure that the necessary design considerations have been incorporated into each application, completely adhering to applicable laws, performance and safety requirements, regulations, codes and standards. The customer is responsible for all consequences of the application.

IMPORTANT : Ce document ne fournit que des instructions d'installation. Reportez-vous au Manuel Utilisateur #SR2MAN01FR pour des instructions concernant outre l'installation, le fonctionnement et la partie logicielle Zelio 2. Les responsables de l'application, de la mise en œuvre ou de l'utilisation de ce produit doivent s'assurer que les considérations nécessaires de conception ont été incorporées à chaque application, en parfaite adéquation aux lois, aux besoins de performance et de sécurité, la réglementation, aux normes et standards. Le client est responsable des conséquences de son application.

IMPORTANTE: Este documento solo contiene instrucciones para la instalación. Consulte el manual de instrucciones # SR2MAN01SP para obtener informaciones más allá de la instalación, del funcionamiento y del programa Zelio 2. Los responsables de la aplicación, implementación o uso de este producto deben asegurarse que las consideraciones de diseño necesarias han sido incorporadas en cada aplicación, completamente de acuerdo con las leyes, requerimientos de rendimiento y seguridad, regulaciones, códigos y modelos aplicables. El cliente esta responsable de la consecuencia de su aplicación.

⚠ DANGER	⚠ DANGER	⚠ PELIGRO
HAZARD OF ELECTRIC SHOCK, EXPLOSION OR ARC FLASH - Turn power off before installing, removing, wiring or maintaining. Failure to follow this instruction will result in death or serious injury.	RISQUE D'ELECTROCUTION, D'EXPLOSION OU D'ARC ELECTRIQUE - Coupez l'alimentation avant d'installer, de câbler ou d'effectuer une opération de maintenance. Le non-respect de cette instruction entraînera la mort ou des blessures graves.	RIESGO DE ELECTROCUCION, DE EXPLOSION O DE ARCO - Desconecte la alimentación antes de realizar los procesos de instalación, cableado, o mantenimiento. Si no se respetan estas instrucciones, se producirán graves daños corporales o la muerte.
⚠ WARNING	⚠ AVERTISSEMENT	⚠ ADVERTENCIA
EXPLOSION HAZARD - According to CSA C22.2 No 213: This equipment is suitable for use in class I, division 2, groups A, B, C and D or non-hazardous locations only. Substitution of components may impair suitability for class I, division 2. - Confirm that the product power supply voltage and its tolerances are compatible with those of the network. - Do not disconnect equipment unless power has been switched off or the area is known to be non-hazardous. UNINTENDED EQUIPMENT OPERATION - This product is not intended for use in safety critical machine functions. Where personnel and or equipment hazard exist, use appropriate hard-wired safety interlocks. - Do not disassemble, repair or modify the controllers. - This controller is designed for use within an enclosure according to specifications described in these instructions in the paragraph on installation conditions. - Install the controllers in the operating environment conditions described below. Failure to follow this instruction can result in death, serious injury or equipment damage.	RISQUE D'EXPLOSION - Selon CSA C22.2 No 213: cet équipement est acceptable pour utilisation dans les endroits dangereux de classe I, division 2, groupes A, B, C et D ou non classifiés seulement. Le remplacement des composants peut affecter l'utilisation en classe I, division 2. - Assurez-vous que la tension d'alimentation du produit, avec ses tolérances, est compatible avec celles du réseau. - Assurez-vous que l'alimentation est coupée ou que la zone ne présente aucun danger avant de connecter l'équipement. OPERATION D'EQUIPEMENT NON INTENTIONNELLE - Ce produit ne doit pas être utilisé dans des fonctions critiques de machine de sûreté. Là où il existe des risques pour le personnel et/ou le matériel, utilisez les contacts de sécurité câblés appropriés. - Veuillez ne pas démonter, réparer, ni modifier le contrôleur. - Ce contrôleur logique doit être utilisé dans une enceinte fermée, selon les spécifications décrites dans cette notice, au paragraphe Conditions d'installation. - Installez les contrôleurs dans un environnement de fonctionnement normal, comme indiqué. Le non-respect de cette directive peut entraîner la mort, des lésions corporelles graves ou des dommages matériels.	RIESGO DE EXPLOSION - Segun CSA C22.2 No 213: Este aparato esta preparado para trabajar dentro de ambientes peligrosos de clase I, Division 2, grupos A, B, C, y D o unicamente en lugares no peligrosos. Reemplazar componentes puede perjudicar la adecuación para la clase I, división 2. - Asegúrese de que la tensión de alimentación del producto y sus tolerancias son compatibles con las de la red eléctrica. - No conecte el equipo a menos que se haya eliminado la alimentación o que la zona no sea peligrosa. OPERACION DEL EQUIPO INVOLUNTARIA - Este producto no esta diseñado para un uso en funciones críticas de una maquina de seguridad. Donde existan riesgos para el personal o el equipamiento, use cierres de seguridad cableados adaptados. - No desmonte, repare ni modifique los productos. - Este producto esta diseñado para un uso en un recinto cerrado, según las especificaciones que se describen en estas instrucciones, al apartado Condiciones de Instalación. - Instale los productos en las condiciones de entorno de funcionamiento descritas. Si no se respetan estas precauciones pueden producirse graves lesiones, daños materiales o incluso la muerte.

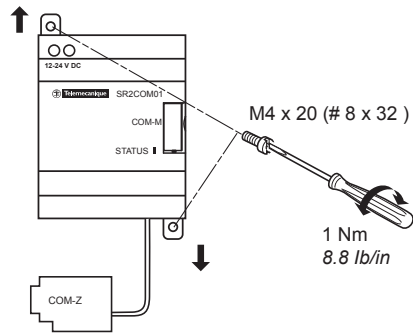
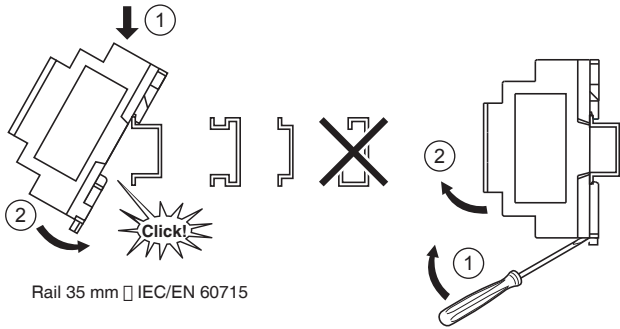

mm inch					
mm ²	0.25...2.5	0.25...0.75	0.2...2.5	0.2...2.5	0.2...1.5
AWG	24...14	24...18	25...14	25...14	25...16

 Ø 3,5 (0.14 in)	C	Nm	0,5
		lb-in	4.5

Installation conditions / Conditions d'installation / Condiciones de instalación

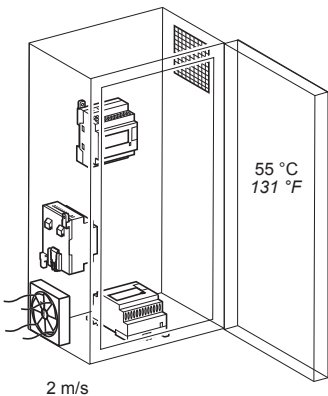

Power factor (CSA Certification) 25 %
Facteur de marche (Certification CSA) 25 %
Factor de marcha (Certificación CSA) 25 %

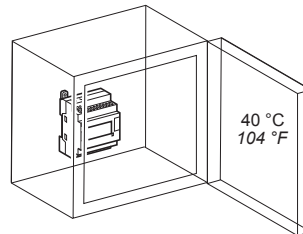

Service conditions

Conditions de fonctionnement

Condiciones de funcionamiento

Operating temperature	-20...+55 °C (-4 °F...+131 °F)	Température de fonctionnement	-20...+55 °C	Temperatura de funcionamiento	-20...+55 °C
Storage temperature	-40...+70 °C (-40 °F...+158 °F)	Température de stockage	-40...+70 °C	Temperatura de almacenamiento	-40...+70 °C
Relative Humidity	Level RH1, 30...95 % (non-condensing)	Humidité relative	Niveau RH1, 30...95 % (sans-condensation)	Humedad relativa	Nivel RH1, del 30...95 % (no condensante)
Pollution Degree	2 (IEC/EN 61131-2)	Degré de pollution	2 (IEC/EN 61131-2)	Grado de contaminación	2 (IEC/EN 61131-2)
Degree of Protection	IP 20 (IEC 60529)	Degré de protection	IP 20 (IEC 60529)	Grado de protección	IP 20 (IEC 60529)
Altitude	Operations: 0...2000 m (0...6562 ft) Transport: 0...3048 m (0...10000 ft)	Altitude	Fonctionnement : 0...2000 m Transport : 0...3048 m	Altitud	Utilización : 0...2000 m Transporte : 0...3048 m
Vibration resistance (IEC 60068-2-6)	Mounting on rail or panel 5...9 Hz, amplitude: 3,5 mm (0.14 in) 9...150 Hz, acceleration: 1 g 10 cycles/axis, 1 octave/minute	Tenue aux vibrations (IEC 60068-2-6)	En montage sur rail et panneau : 5...9 Hz, amplitude : 3,5 mm, 9...150 Hz, accélération : 1 g 10 cycles/axe, 1 octave/minute	Resistencia a las vibraciones (IEC 60068-2-6)	En montaje en carril y panel 5...9 Hz, amplitud: 3.5 mm 9...150 Hz, aceleración: 1 g 10 cyclos/eje, 1 octava/minuto
Shock resistance (IEC 60068-2-27)	147 m/sec ² (15 g), 11 ms duration, 3 shocks per axis.	Tenue aux chocs (IEC 60068-2-27)	147 m/sec ² (15 g), durée 11 msec, 3 chocs par axe sur les trois axes	Resistencia mecanica a los golpes (IEC 60068-2-27)	147 m/sec ² (15 g), duración 11 msec, 3 golpes por eje.
Enclosure material	Self-extinguishable	Matière boîtier	Auto-extinguible	Material caja	Autoextinguible
Standard applicable/ operating conditions	IEC/EN 61131-2	Normes applicables/ conditions de fonctionnement	IEC/EN 61131-2	Norma de aplicación/ condiciones de funcionamiento	IEC/EN 61131-2

**Wiring architecture / Architecture câblage / Verkabelungsarchitektur /
Architettura di cablaggio / Arquitectura de cableado / Esquema de ligação**

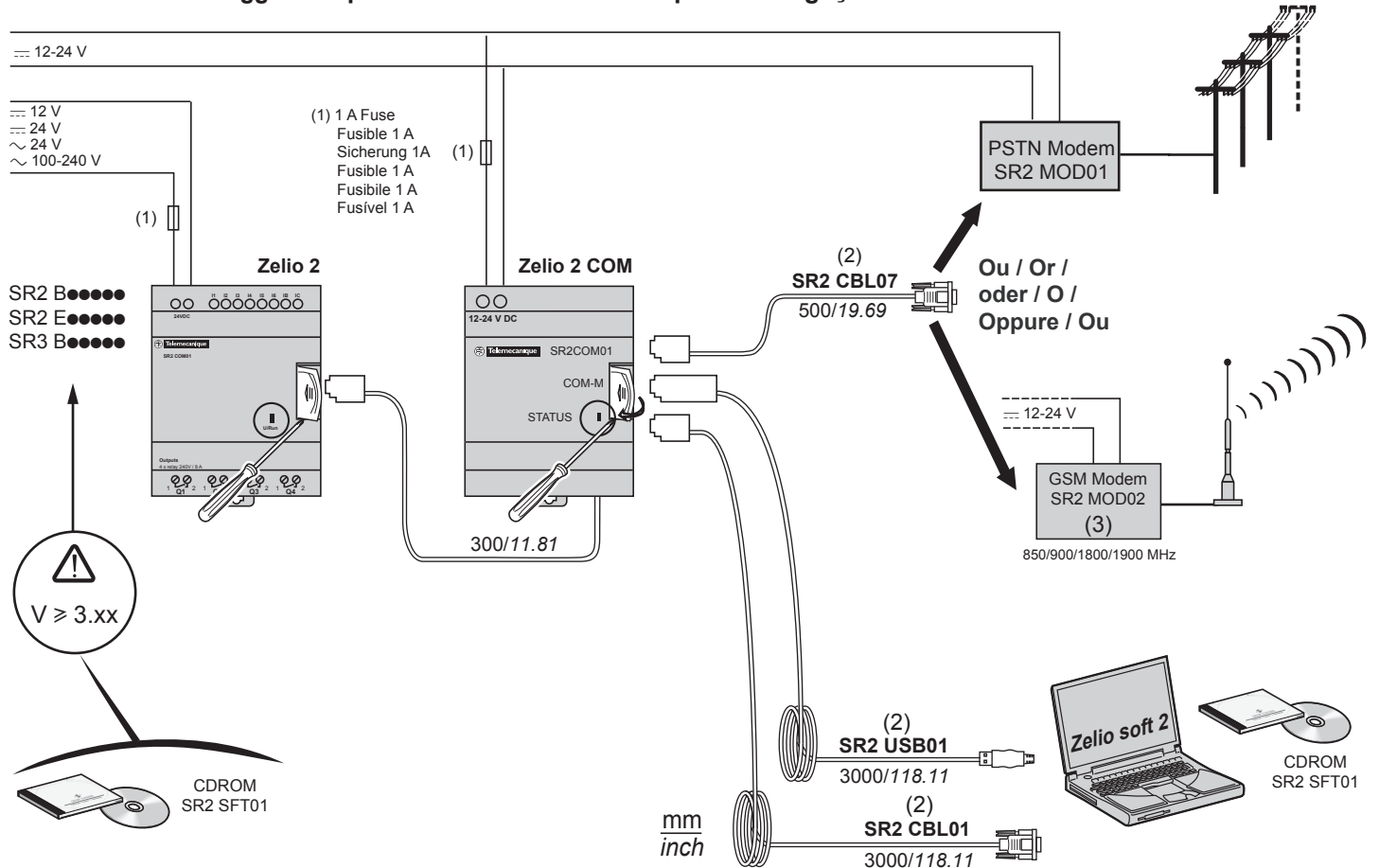

(2) Only use specified cable
Utiliser uniquement les câbles spécifiques
Ausschließlich das spezielle Kabel verwenden
Utilizar únicamente el cable específico
Utilizzare soltanto il cavo specifico
Utilizar unicamente o cabo específico

(3) Utilization of the SR2 MEM01/02 is incompatible with the SR2 COM1.
L'usage de la SR2 MEM01/02 est incompatible avec le SR2 COM1
SR2 MEM01/02 ist mit SR2 COM1 nicht kompatibel
El uso de la SR2 MEM01/02 es incompatible con el SR2 COM1.
L'uso della SR2 MEM01/02 è incompatibile con l'SR2 COM1
A utilização da SR2 MEM01/02 é incompatível com a SR2 COM1.

**Wiring architecture for Zelio Logic Alarm use / Architecture câblage pour utilisation Zelio Logic Alarm /
Verkabelungsarchitektur für die Verwendung von Zelio Logic Alarm /
Arquitectura Cableado para utilización Zelio Logic Alarm /
Architettura cablaggio e architettura cablaggio per utilizzo allarme logico ZELIO /
Esquema de ligação para utilização Zelio Logic Alarm**

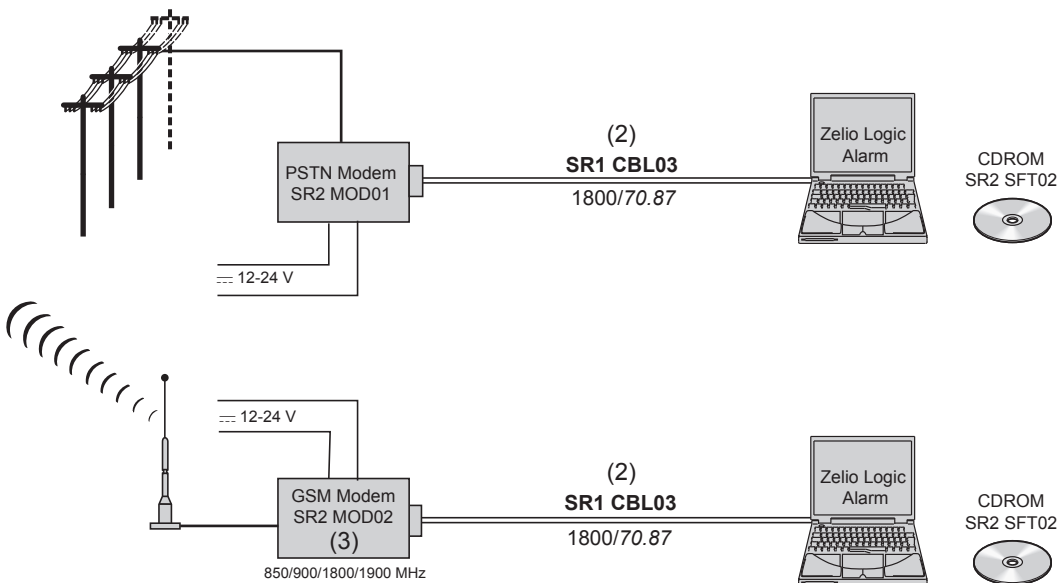

(3) Not recommended for Japan / Non recommandé pour le Japon /
Für Japan nicht geeignet / No se recomienda para Japón /
Non consigliato per Giappone / Não recomendado no Japão.

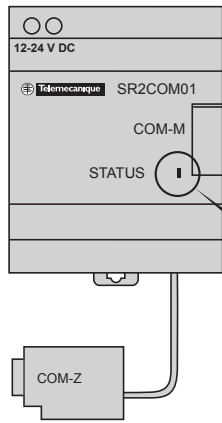

SR2COM01 STATUS		Green / Vert / Grün / Verde / Verde / Verde			Yellow / Jaune / Gelb / Giallo / Amarillo / Amarelo		
Status / Etat / Status / Stato / Estado / Estado		⊗	⊗	⊗	⊗	⊗	⊗
1	No power	⊗	-	-	⊗	-	-
2	Modem fault	-	-	-	-	-	⊗
3	Zelio 2 fault	-	-	-	-	⊗	-
4	Internal fault	-	-	-	-	⊗	-
5	Zelio 2 and modem detected	-	-	⊗	-	-	-
6	COM-M dialog in progress	-	⊗	-	-	-	-
7	Zelio Soft 2 dialog in progress/Message OFF	-	⊗	-	-	⊗	-

	FR	DE	ES	IT	PT
1	Non alimenté	Keine Stromversorgung	No alimentado	Non alimentato	Sem Alimentação
2	Défaut Modem	Modemfehler	Fallo Módem	Guasto modem	Falha do Modem
3	Défaut Zelio 2	Zelio 2-Fehler	Fallo Zelio 2	Guasto Zelio 2	Falha do Zelio 2
4	Défaut interne	Interner Fehler	Fallo interno	Guasto interno	Falha interna
5	Zelio 2 et modem détectés	Zelio 2 und Modem ermittelt	Zelio 2 y Módem detectados	Zelio 2 e modem rilevati	Zelio 2 e modem detectados
6	Dialogue COM-M en cours	COM-M-Dialog wird aufgebaut	Diálogo COM-M en curso	Dialogo COM-M in corso	Diálogo COM-M em curso
7	Dialogue Zelio Soft 2 en cours/Message OFF	Zelio Soft 2-Dialog wird aufgebaut/ Meldung AUS	Diálogo Zelio Soft 2 en curso/ Mensaje OFF	Dialogo Zelio Soft 2 in corso/ Messaggio OFF	Dálogo Zelio Soft 2 em curso/ Mensagem DESLIGADO

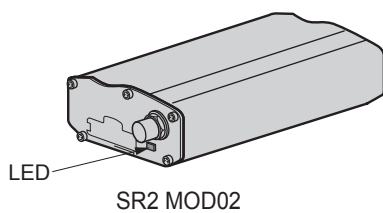

SR2 MOD02 LED		Yellow / Jaune / Gelb / Giallo / Amarillo / Amarelo		
Status / Etat / Status / Stato / Estado / Estado		⊗	⊗	⊗
1	Not ready	⊗	-	-
2	Ready but not connected to network	-	-	⊗
3	Ready and connected to network	-	⊗	-
4	Transmission mode	-	⊗	-

	FR	DE	ES	IT	PT
1	Non prêt	Nicht betriebsbereit	No listo	Non pronto	Não preparado
2	Prêt mais non connecté au réseau	Betriebsbereit, aber nicht mit Netzwerk verbunden	Listo pero no conectado a la red	Pronto ma non connesso alla rete	Preparado mas não ligado à rede
3	Prêt et connecté au réseau	Betriebsbereit und mit Netzwerk verbunden	Listo y conectado a la red	Pronto e connesso alla rete	Preparado e ligado à rede
4	Mode de transmission	Übertragungsmodus	Modo transmisión	Modalità di trasmissione	Modo de transmissão

Schneider Electric Modem

User Guide

EG_SR2MOD0x_SE_1002_UG_000_UK
04/2008



Document history

Revision	Modifications	Author	Date
000	CREATION (VERSION UK)	F. LE BRETON	16/04/08

The main modifications in this document compared to its previous version, are easily identifiable on a monitor by means of the blue text.

CONTENTS

PRESENTATION.....	6
HAZARD CATEGORIES AND SPECIAL SYMBOLS.....	7
COPYRIGHT AND DISCLAIMER.....	9
1 REFERENCES.....	10
1.1 PRODUCTS REFERENCES.....	10
1.2 ABBREVIATIONS.....	11
2 PACKING.....	13
2.1 CONTENTS.....	13
2.2 PACKING CASE.....	14
2.3 MODEM LABELS.....	14
3 GENERAL PRESENTATION.....	15
3.1 PHYSICAL DESCRIPTION.....	15
3.2 EXTERNAL CONNECTIONS.....	16
3.2.1 Connections.....	16
3.2.1.1 GSM antenna connector.....	16
3.2.1.2 4-pins Micro FIT female connector.....	16
3.2.1.3 9-pins Sub-D female connector.....	16
3.2.2 Accessories.....	17
3.2.2.1 2-wires micro FIT supply cable.....	17
3.2.2.2 GSM magnetic Antenna (SMA-M).....	17
4 USING THE MODEM.....	18
4.1 STARTING WITH THE MODEM.....	18
4.1.1 Mounting/Removal.....	18
4.1.1.1 Using DIN (35 mm) Rail mounting clip.....	18
4.1.1.2 Mounting the modem with 2 mounting brackets.....	19
4.1.2 Modem Installation.....	19
4.1.3 Network Bands Scanning.....	20
4.1.4 GSM LED.....	20
4.1.5 Modem configuration PC side under Windows XP.....	21
5 MODEM COMMUNICATION.....	26
5.1 VERIFYING MODEM COMMUNICATION.....	26
5.2 AT COMMANDS ECHO DEACTIVATED.....	27
5.3 VERIFYING GSM RECEIVE SIGNAL QUALITY.....	28
5.4 VERIFYING THE PIN CODE.....	29
5.5 VERIFYING MODEM REGISTRATION ON THE GSM NETWORK.....	29
5.6 MAIN AT COMMANDS (HAYES).....	30
5.7 POWERING DOWN THE UNIT.....	31
5.8 RS232 (V24) COMMUNICATION PROBLEM.....	31
5.9 "ERROR" MESSAGE.....	32
5.10 "NO CARRIER" MESSAGE.....	32
6 FUNCTIONAL DESCRIPTION.....	34
6.1 ARCHITECTURE.....	34
6.2 POWER SUPPLY.....	34
6.2.1 General.....	34
6.2.2 Protections.....	34
6.3 RS232 SERIAL LINK.....	35
6.3.1 General.....	35
6.3.2 Mode Autobauding.....	36
6.3.3 Pins description.....	36
7 TECHNICAL CHARACTERISTICS.....	37

7.1 MECHANICAL.....	37
7.2 ELECTRICAL.....	38
7.2.1 Power supply	38
7.2.2 Interface SIM.....	39
7.2.3 GSM/DCS	39
7.2.3.1 Frequency bands	39
7.2.3.2 RF Performances	39
7.2.3.3 External GSM Antenna.....	40
7.3 ENVIRONMENTAL CHARACTERISTICS.....	40
7.4 STANDARDS / CONFORMITIES	40
7.5 PROTECTIONS.....	41
7.5.1 Power supply	41
7.5.2 Over-voltage	41
7.5.3 ESD	41
7.5.4 Miscellaneous	41
8 SECURITY RECOMMENDATIONS	42
8.1 GENERAL.....	42
8.2 SECURITY IN A VEHICLE	43
8.3 CARE AND MAINTENANCE.....	43
8.4 YOUR RESPONSIBILITY.....	43

Presentation

Entirely dedicated to the wireless markets throughout the world, the Modem allows a simple and rapid integration of GSM / GPRS connectivity into M2M applications.

The Modem used the Wavecom Module Quad-Band version 850/900/1800/1900 MHz (Europe Bands: 900/1800 MHz and US Bands: 850/1900 MHz) and GSM/GPRS Class 10.

The Modem references are according to ranges as follows:



- **Smart Relays:** Zelio Logic of Schneider Electric
 - Modem reference: SR2 MOD02
 - Identified by marking on the Modem and the labels
- **Programmable Controllers:** Twido of Schneider Electric
 - Modem reference: SR2 MOD03
 - Identified by marking on the Modem and the labels.

Hazard Categories and Special Symbols

The following symbols and special messages may appear in this manual or on the equipment to warn of potential hazards or to call attention to information that clarifies or simplifies a procedure.

A lightning bolt or ANSI man symbol in a “Danger” or “Warning” safety label on the equipment indicates an electrical hazard which, as indicated below, can or will result in personal injury if the instructions are not followed.

The exclamation point symbol in a safety message in a manual indicates potential personal injury hazards. Obey all safety messages introduced by this symbol to avoid possible injury or death.

Symbol	Name
	Lightning Bolt
	ANSI Man
	Exclamation Point

DANGER

DANGER indicates an imminently hazardous situation which, if not avoided, **will result in death or serious injury**.

WARNING

WARNING indicates a potentially hazardous situation which, if not avoided, **can result in death or serious injury**.

CAUTION

CAUTION indicates a potentially hazardous situation which, if not avoided, **can result in minor or moderate injury**.

CAUTION

CAUTION used without the safety alert symbol, indicates a potentially hazardous situation which, if not avoided, **can result in property damage**.

WARNING

LOSS OF CONTROL

- The designer of any control scheme must consider the potential failure modes of control paths and, for certain critical control functions, provide a means to achieve a safe state during and after a path failure. Examples of critical control functions are emergency stop and overtravel stop.
- Separate or redundant control paths must be provided for critical control functions.
- System control paths may include communication links. Consideration must be given to the implications of unanticipated transmission delay or failures of the links.¹
- Each implementation of a SR2 MOD02 or SR2 MOD03 modem must be individually and thoroughly tested for proper operation before being placed into service.

Failure to follow these instructions can result in death, serious injury, or equipment damage.

¹ For additional information, refer to NEMA ICS 1.1 (latest edition), "Safety Guidelines for the Application, Installation, and Maintenance of Solid State Control"

WARNING

HAZARD OF ELECTRIC SHOCK OR BURNS

- Do not open the modem.
- Modem must be powered using a 5 to 32 VDC power supply in GSM/DCS Class 2 (5.5 to 32 VDC in GPRS Class 10) using the supplied power cable.
- No internal user serviceable parts.
- Modem must be returned to the factory for any repairs.

Failure to follow these instructions can result in death, serious injury, or equipment damage.

CAUTION

EQUIPMENT DAMAGE

- Do not connect a supply voltage to pins 3 and 4.
- Do not use pins 3 and 4.

Failure to follow these instructions can result in death, serious injury, or equipment damage.

DANGER

UNINTENDED EQUIPMENT OPERATION

The GSM modem must be turned off in the following situations:

- On an aircraft. The use of cellular telephones can be hazardous to the operations of the plane, disturb the cellular network, and is illegal. The non-observance of this instruction can lead to the suspension of cellular telephone services as well as a fine.
- At a refueling station.
- In any area with a potentially explosive atmosphere which could lead to an explosion or fire.
- In hospitals and similar places where medical equipment may be in use.

Failure to follow these instructions will result in death, serious injury, or equipment damage.

Copyright and Disclaimer

All rights reserved. The reproduction, transfer, distribution or storage of part or the totality of the contents of this document, in any form, mechanical or electronic, without the prior written authorization from Schneider Electric is strictly prohibited.

Hayes is a registered trademark of Hayes Microcomputer Product Inc. The names of products and companies mentioned in this document may be names or trademarks of their respective holders.

Use of certain products or services described in this document may require subscription or a paying subscription. The availability of certain products or services described in this document can vary according to the configurations and the materials.

In certain countries, restrictions of use of the equipment may apply. Contact your nearest legally qualified local government representative for more information.

Schneider Electric operates a method of continuous development. Consequently, Schneider Electric reserves the right to change and improve its products and documentation at any time and without notice.

The contents of this document are provided "as is". All information contained herein is provided in good faith. No responsibility can be assumed as to the precision and reliability of the contents of this document. Except for the applicable obligatory laws, no guarantee in any form, explicit or implicit, including, but without being limited to it, is granted as to the aptitude for marketing and suitability to a particular use. Schneider Electric reserves the right to revise this document or to withdraw it at any time and without notice.

Schneider Electric cannot in any case to be held responsible for any loss of data or income, as well as particular damage, incidental, consecutive or indirect.

In its continuing research into improving its products, Schneider Electric reserves the right to modify its products and documentation at any time.

PLEASE NOTE:

Electrical equipment should be installed, operated, serviced, and maintained only by qualified personnel. No responsibility is assumed by Schneider Electric for any consequences arising out of the use of this material.

© 2008 Schneider Electric. All Rights Reserved

1 References

1.1 Products References

The various features of the Modem are shown in the table below:

Modem
Functions GSM
- Quad-Bands 900/1800 and 850/1900 MHz
- ETSI GSM Phase 2+ Class 4 (2 W @ 850 / 900 MHz) Class 1 (1 W @ 1800 / 1900 MHz)
- SIM Toolkit Release 99
DATA Features
- GPRS Class 10 (up to 4Rx / 2Tx)
- Supports PBCCH, Coding schemes: CS1 à CS4
- TCP/IP Library (PPPRFC, TCP Socket, UDP Socket, SMTP, POP3, FTP)
- Asynchronous data circuit, transparent and non-transparent, 9600 bps (standard) up to 14400 bps (depending on network)
- Compatible Fax Group 3
- SMS point to point MT/MO and SMS CB
Memory Type
- Flash 32 Mbits and SRAM 4 Mbits (32/4)
Interfaces
- Antenna GSM: SMA-F connector
- Power Supply: +5.5 to +32 VDC (micro-FIT connector)
- RS232 + Audio via female 9-pin Sub-D connector
- AT Commands: GSM 07.05 and 07.07
- SIM reader (SIM 3 V – 1.8 V)
- DIN (35 mm) Rail mounting Clip
Supplied Accessories
- Mounting brackets (x2)
- Power Supply cable - 2-wire Micro FIT
- GSM magnetic Antenna (SMA-M)

1.2 Abbreviations

AC	Alternating Current
ACM	Accumulated Call Meter
AT	ATtention (prefix for modem commands)
BTS	Base Transceiver Station
CLK	CLock
CMOS	Complementary Metal Oxide Semiconductor
CS	Coding Scheme
CTS	Clear To Send
dB	Decibel
dBc	Decibel relative to the Carrier power
dB_i	Decibel relative to an Isotropic radiator
dB_m	Decibel relative to one milliwatt
DC	Direct Current
DCD	Data Carrier Detect
DCE	Data Communication Equipment
DCS	Digital Cellular System
DSR	Data Set Ready
DTE	Data Terminal Equipment
DTMF	Dual Tone Multi-Frequency
DTR	Data Terminal Ready
EEPROM	Electrically Erasable Programmable Read-Only Memory
EFR	Enhanced Full Rate
E-GSM	Extended GSM
EMC	ElectroMagnetic Compatibility
EMI	ElectroMagnetic Interference
ESD	ElectroStatic Discharges
ETSI	European Telecommunications Standards Institute
FIT	Series of connectors (micro-FIT)
FR	Full Rate
FTA	Full Type Approval
GCF	Global Certification Forum
GND	GrouND
GPIO	General Purpose Input Output
GPRS	General Packet Radio Service
GSM	Global System for Mobile communications
HR	Half Rate
I	Input
IEC	International Electrotechnical Commission
IMEI	International Mobile Equipment Identification
I/O	Input / Output
LED	Light Emitting Diode
MAX	MAXimum
ME	Mobile Equipment
MIC	MICrophone
MIN	MINimum
MNP	Microcom Networking Protocol
MO	Mobile Originated
MS	Mobile Station
MT	Mobile Terminated
NOM	NOMinal
O	Output
Pa	Pascal (for speaker sound pressure measurements)
PBCCH	Packet Broadcast Control Channel

1 References

PC	Personal Computer
PCL	Power Control Level
PDP	Packet Data Protocol
PIN	Personal Identity Number
PLMN	Public Land Mobile Network
PUK	Personal Unblocking Key
RF	Radio Frequency
RFI	Radio Frequency Interference
RI	Ring Indicator
RMS	Root Mean Square
RTS	Request To Send
RX	Receive
SIM	Subscriber Identification Module
SMA	SubMiniature version A RF connector
SMS	Short Message Service
SNR	Signal-to-Noise Ratio
SPI	Serial Peripheral Interface
SPL	Sound Pressure Level
SPK	SPeaKer
SRAM	Static RAM
TCP/IP	Transmission Control Protocol / Internet Protocol
TDMA	Time Division Multiple Access
TU	Typical Urban fading profile
TUHigh	Typical Urban, High speed fading profile
TX	Transmit
TYP	TYPical
UTC	Universal Time Clock
VSWR	Voltage Stationary Wave Ratio

2 Packing

2.1 Contents

The Modem is supplied with:

- Modem packing case,
- The Modem,
- DIN (35 mm) Rail mounting clip,
- 2 mounting brackets,
- Instructions Sheet,
- 2-wire cable (Red/Black) with in-line fuse,
- GSM magnetic Antenna (SMA-M).

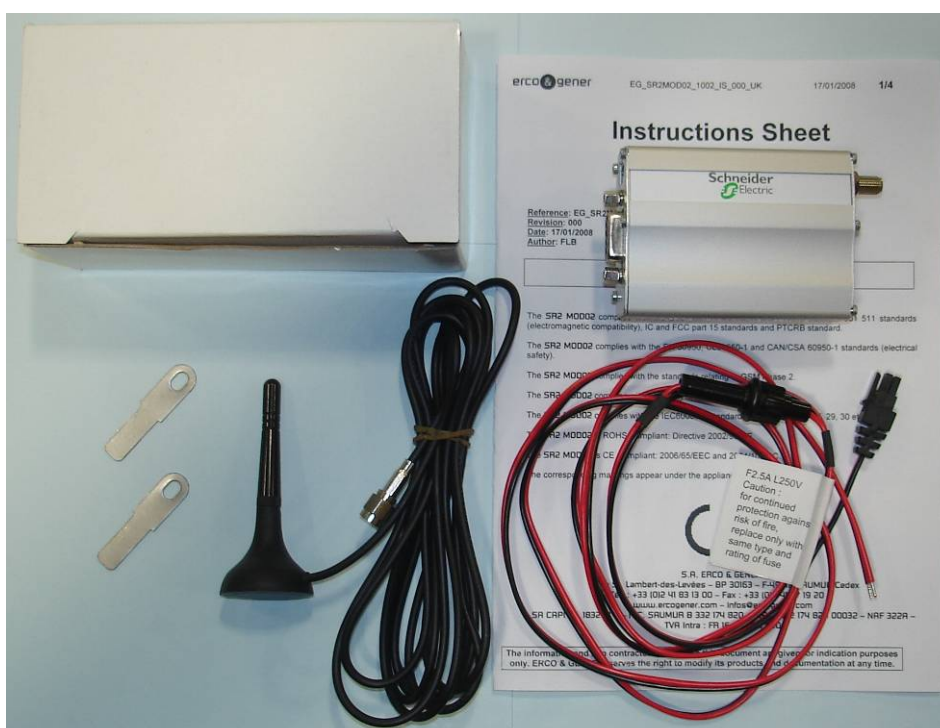

2.2 Packing Case

Packing case external dimensions:

- Width: 70 mm,
- Height: 70 mm,
- Length: 150 mm.

An identification label is affixed on the top of the packing case. It contains:

- The Schneider Electric logo,
- The product reference and information,
- CE mark.

Identification label dimensions:

- Height: 50 mm,
- Length: 80 mm.

2.3 Modem Labels

Two labels are affixed on the bottom part of the modem:

- A production label provides the following information:
 - The product reference,
 - Crossed wheelie-bin mark (DEEE standard),
 - Current, Voltage DC supply (VDC),
 - The IMEI 15-digit bar code,
 - Made by ERCO & GENER.
- Additional marking:
 - ROHS (2002/95/CE),
 - CE mark,
 - CSA,
 - UL,
 - FCC.

3 General Presentation

3.1 Physical Description

Description of the Modem:

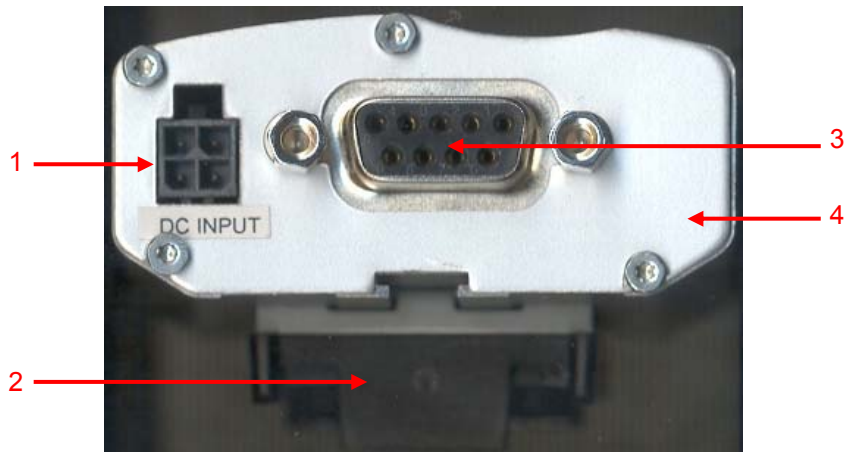

N°	Description
1	Connector Micro-Fit 4-pins/M
2	DIN (35 mm) Rail Mounting clip
3	Connector Sub-D 9 pins/F
4	Front side

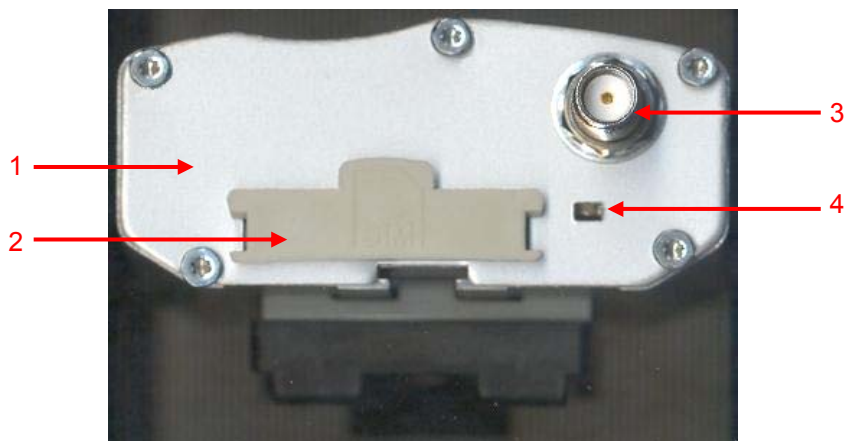

N°	Description
1	Rear side
2	SIM Card Cover
3	Connector SMA/F (GSM antenna)
4	GSM LED (see § 4.1.4)

3.2 External connections

3.2.1 Connections

3.2.1.1 GSM antenna connector

The GSM antenna connector is a 50 Ohms impedance female SMA type.

3.2.1.2 4-pins Micro FIT female connector

This connector allows the connection of an external DC supply.

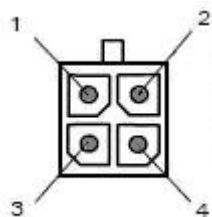

Pin N°	Signal
1	+VDC
2	GND
3	NC
4	NC

⚠ CAUTION

EQUIPMENT DAMAGE

- Do not connect a supply voltage to pins 3 and 4.
- Do not use pins 3 and 4.

Failure to follow these instructions can result in death, serious injury, or equipment damage.

3.2.1.3 9-pins Sub-D female connector

The 9-pins Sub-D female connector is used to connect the RS232 serial link.

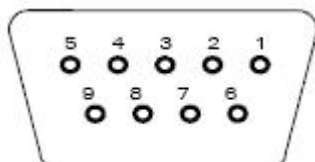

PIN N°	Designation	Circuit (V24 – RS232C)	I/O
1	Signal detection	109 – DS – DCD	O
2	Data reception	104 – RD – RXD	O
3	Data transmission	103 – ED – TXD	I
4	Data Terminal Ready	108/2 – TDP – DTR	I
5	Ground	102 – TS – GND	-
6	Data Set Ready	107 – PDP – DSR	O
7	Request To Send	105 – DPE – RTS	I
8	Clear To Send	106 – PAE – CTS	O
9	Ring Indicator	125 – IA – RI	O

3.2.2 Accessories

3.2.2.1 2-wires micro FIT supply cable

The cable described below is supplied with the modem.

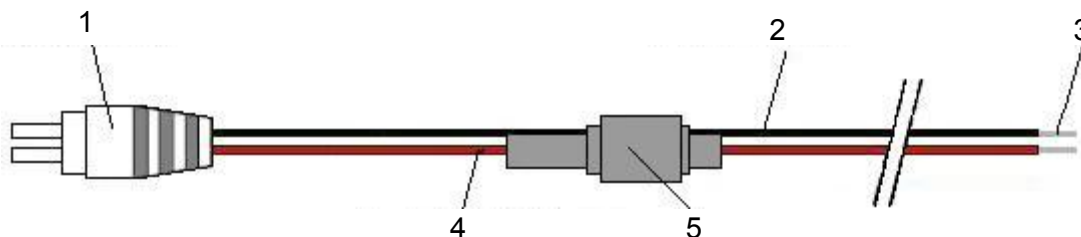

N°	Description
1	4-pin Micro FIT connector
2	Black wire (GND)
3	5 mm tinned copper wire
4	Red wire (+VDC)
5	Fuse 2.5 A/250 V Fast Blow (5x20 mm)

View from cable side

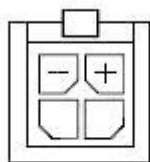

Component	Characteristics
Micro FIT connector	Male 4-pin
Cable	Length \approx 1.5 m
Wire	Tinned copper 24 x 0.2 mm
	Wire gauge: 0.75 mm ²

3.2.2.2 GSM magnetic Antenna (SMA-M)

The GSM magnetic antenna is designed for a vertical use and must be put on a metallic support.

Its connection SMA Male allows it to be directly connected to the modem.



Component	Characteristics
Magnetic SMA-M Antenna	Quad Bands 850/900/1800/1900 MHz
Coaxial Cable	Length \approx 2.5 m \pm 10 cm
	RG174 - \varnothing 2.54 mm
Antenna Dimensions	Base: \varnothing 30 mm Total Height: 7 cm

4 Using the modem

4.1 Starting with the modem

4.1.1 Mounting/Removal

4.1.1.1 Using DIN (35 mm) Rail mounting clip

The modem is supplied with a DIN (35 mm) Rail mounting clip mounted on the case.

The DIN (35 mm) Rail mounting clip allows a fast and easy mounting/removal on an OMEGA DIN (35 mm) Rail (IEC/EN 60715 / DIN (35 mm) 7.5 mm).

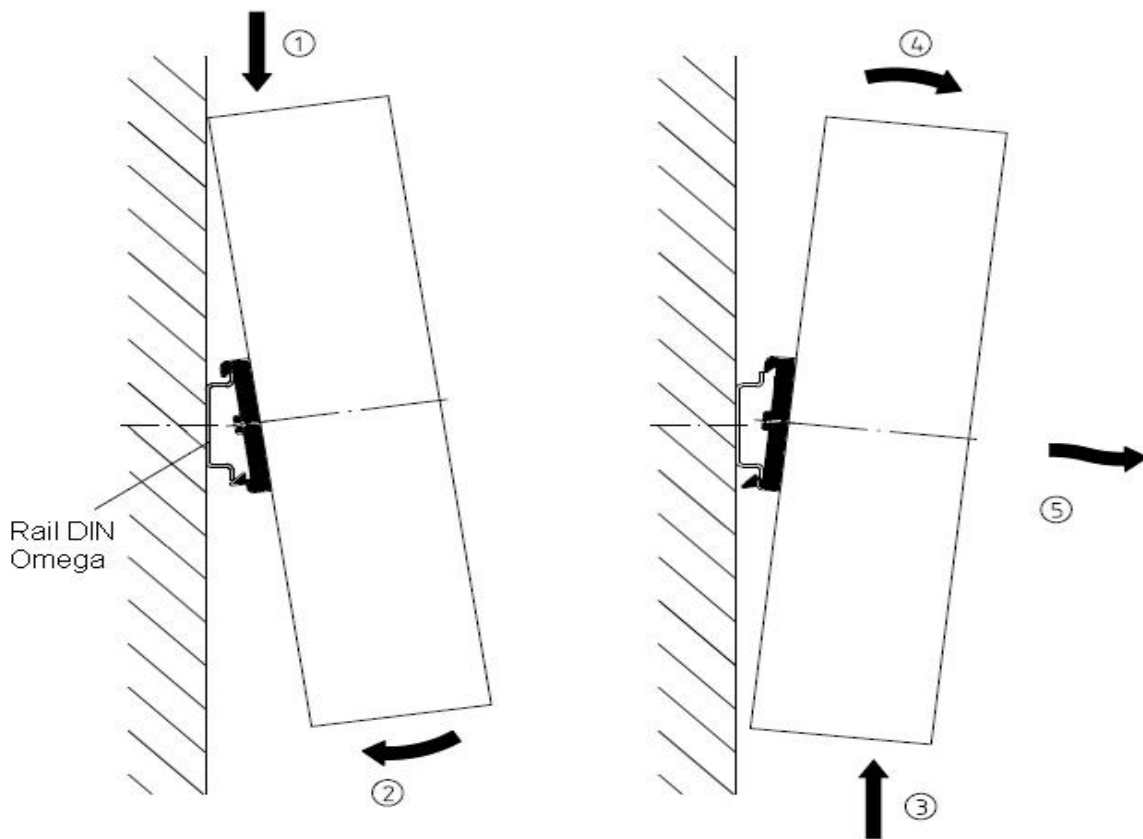

Step	Action	
1	Mounting the modem	Press the modem on DIN (35 mm) Rail.
2		Rotate to lock the modem on the Rail.
3	Removing the modem	Press the modem on DIN (35 mm) Rail.
4		Rotate to unlock the modem on the Rail.
5		Take out the modem.

4.1.1.2 Mounting the modem with 2 mounting brackets

To mount the modem on a support, use the mounting brackets as shown in the diagram below:

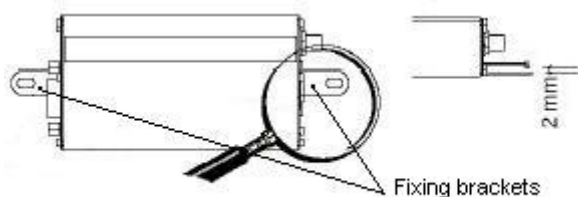

Note:
 - Must be mounted to a flat surface.
 - Maximum height of the screw head height: 2 mm

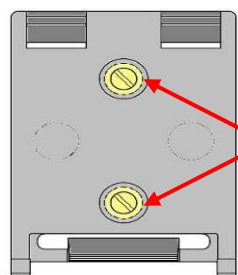

Screws must be unscrewed for removal

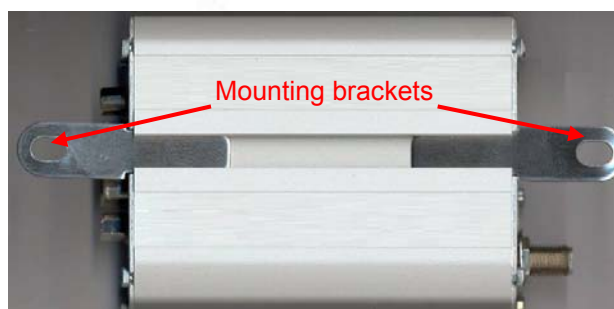

Step	Action
1	Remove the 2 DIN (35 mm) Rail mounting clip screws.
2	Slide the support of the DIN (35 mm) Rail clip.
3	Insert the 2 mounting brackets.

4.1.2 Modem Installation

To install the modem, it is recommended to perform the following operations with the modem turned off:

Step	Action
1	Remove the SIM card cover on the rear side
2	Carefully insert the SIM card into its holder.
3	Put the SIM card cover on the rear side.
4	Connect the GSM antenna to the SMA connector.
5	Plug the 9-pins Sub-D connector of modem to the device by using the RS232 cable.
6	Connect the supply cable to an external regulated DC source.
7	Connect the supply cable to the modem and turn on the power supply. The modem will control the network bands and the GSM LED will light up.

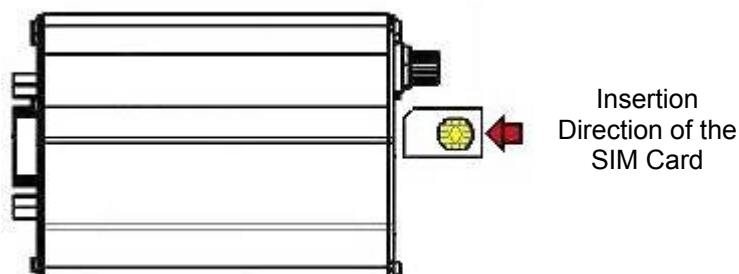

The modem is now ready for use. If you used a PC (Terminal), refer to the chapter 5 for a description of the commands for configuring and using the modem.

4.1.3 Network Bands Scanning

By default, the modem is configured to first automatically check the European network bands.

After insertion of SIM card Network bands scanning is activated. An embedded application automatically checks the presence of a network. In case of absence, it switches to the US network bands and continues its search. This cycle is repeated until a valid network is found.

The detected GSM network is stored in the modem.

In the case of use of new SIM card, a new network search procedure is automatically initialized.

Note: In the case of a modem configured with a SIM card for use in a specific area (European area for instance) that is then to be used in a different area (US for instance), the SIM card must be removed while modem is switched on. This is because a new network search procedure is automatically initialized after the removal (or change) of the SIM card while the device is switched on.

4.1.4 GSM LED

The state of the modem is indicated by the GSM LED located on the rear side of the modem (see chapter 3.1). The table below shows the meaning of the different states of the GSM LED:

GSM LED	LED activity	Modem state
ON	LED on fixed	The modem is powered, it is ready to function but not yet recognized by the network; the PIN code has not yet been entered or the antenna is not connected.
	LED flashing (once every 2 seconds)	The modem is powered, the PIN code is active, the modem is recognized by the network and is ready to make or receive a call (Idle mode).
	LED flashing (Once a second)	The modem is powered and currently in communication (Voice, Data or Fax).
OFF	LED off	The modem is not powered or is in the RESET phase.

4.1.5 Modem configuration PC side under Windows XP

In order to use this modem PC side, it is necessary to install and configure this modem under Windows with the same communication parameters: see chapter 5.1.

To add a modem under Windows, follow instructions below:

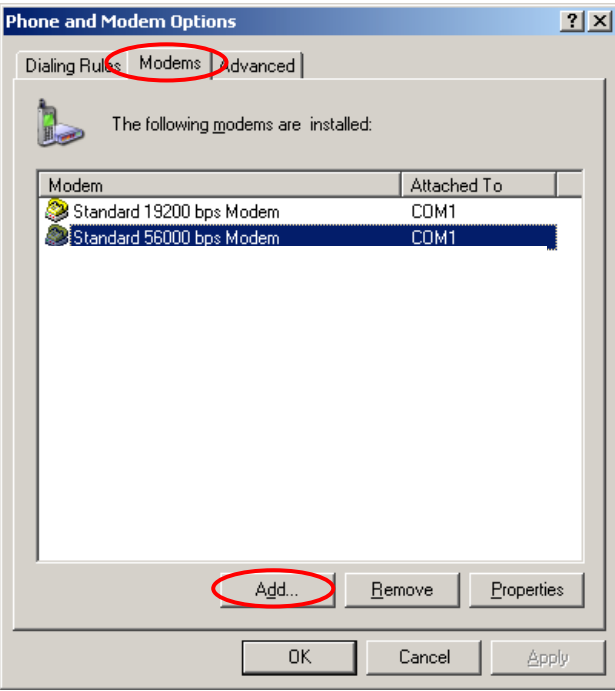
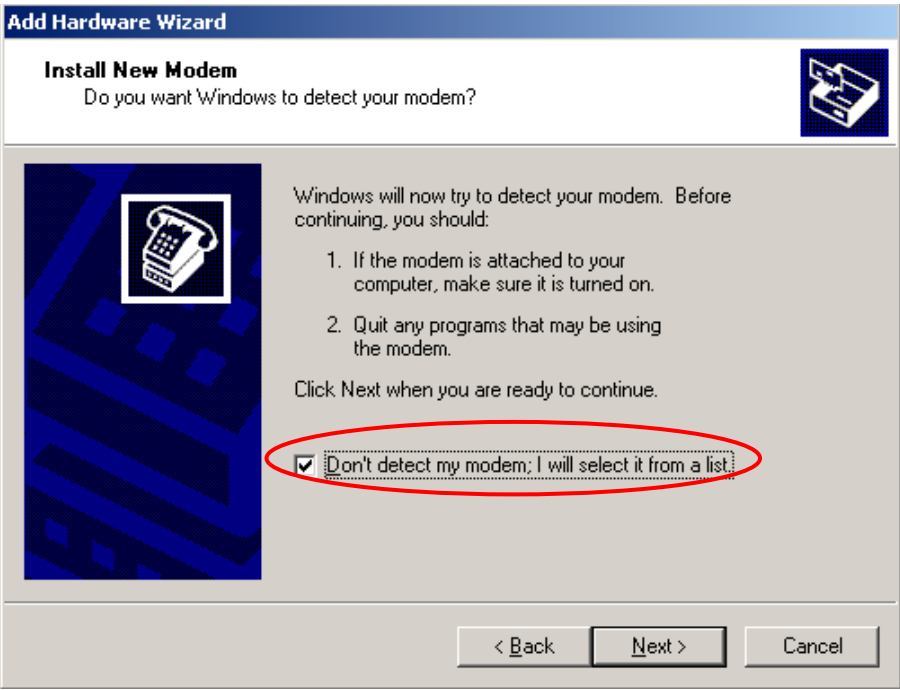
Step	Action
1	<p>In the menu Start, Control panel, select « Phone and Modem Options » The following window appears:</p>  <p>Click on « Modem » then « Add ».</p>
2	<p>The following window appears:</p>  <p>Check the box « Don't detect my modem » and click on Next:</p>

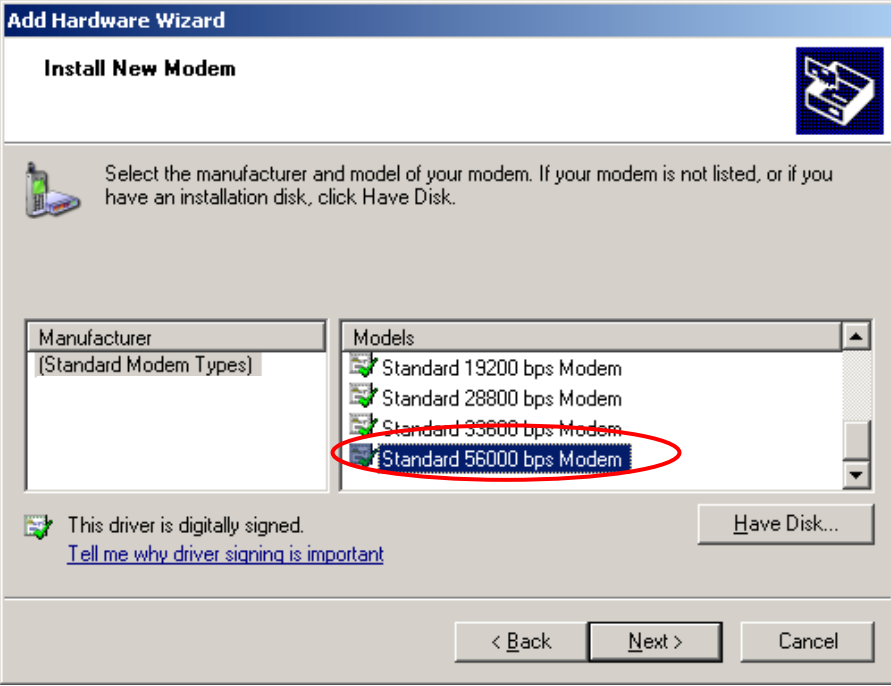
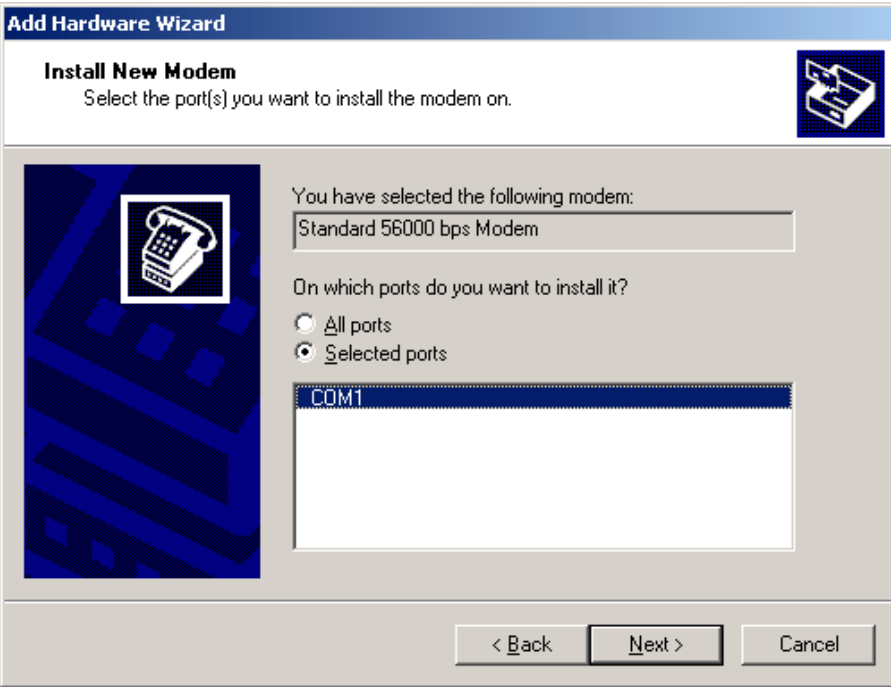
Step	Action
3	 <p>Choose a standard modem 56000 bps and click on « Next ».</p>
4	 <p>Select the communication port where the modem is connected and click on « Next ». Windows installs the modem.</p>

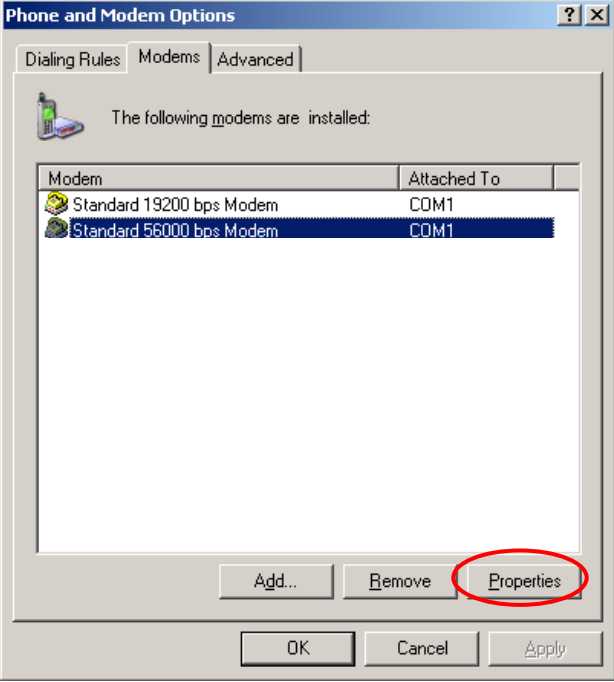
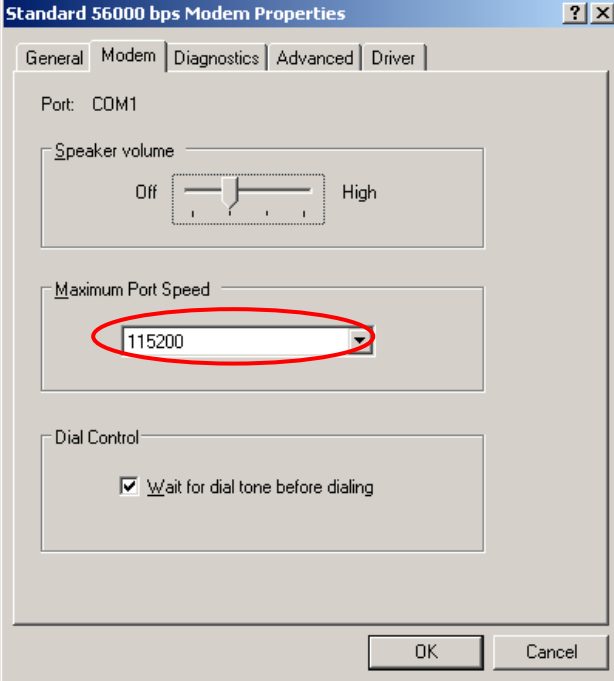
Step	Action
5	<p>After the modem is installed, it is necessary to configure the communication port link to the modem:</p>  <p>Click on standard modem 56000 bps then on « Properties ».</p>
6	<p>Click on « Modem » and select 115200 as maximal port speed.</p>  <p>Click on « Modem » and select 115200 as maximal port speed.</p>

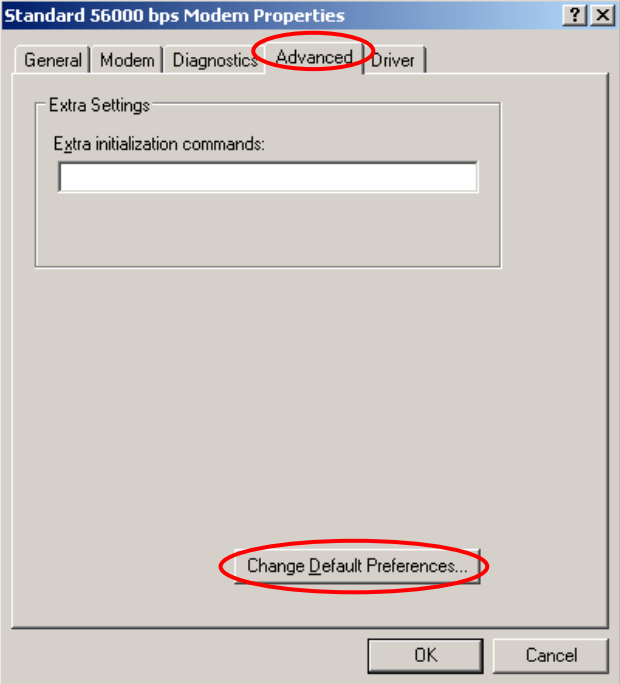
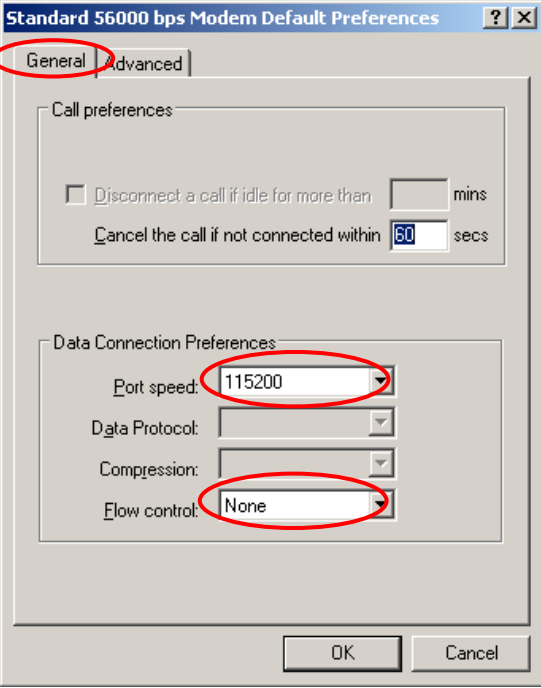
Step	Action
7	<p>Click on « Advanced » then « Change Default Preferences »:</p> 
8	<p>In the menu « General », select 115200 bps and None as Flow Control method.</p> 

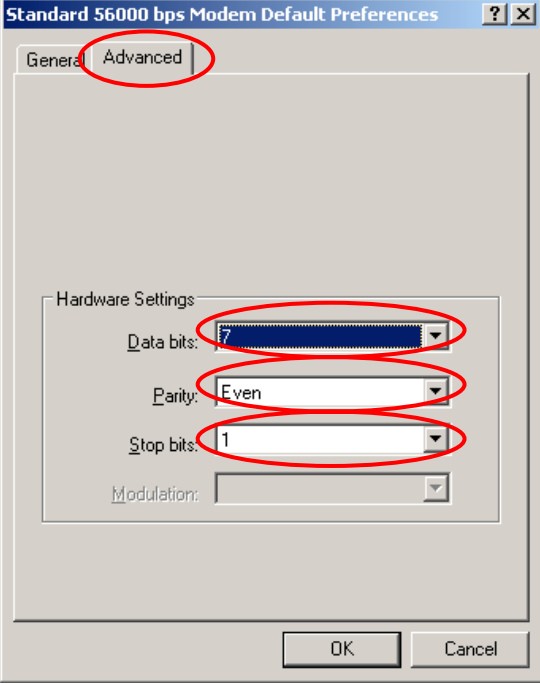
Step	Action
9	<p>Click on « Advanced » and the following window appears:</p> <p>Enter the parameters according to the modem configuration (see chapter 5.1).</p> <p>In the example below, the configuration is for the SR2 MOD02 Modem.</p>  <p>The screenshot shows a dialog box titled "Standard 56000 bps Modem Default Preferences". It has two tabs: "General" and "Advanced". The "Advanced" tab is selected and circled in red. Below the tabs is a "Hardware Settings" section with four dropdown menus: "Data bits" (set to 7), "Parity" (set to Even), "Stop bits" (set to 1), and "Modulation" (set to an empty field). Each of these four dropdown menus is also circled in red. At the bottom of the dialog box are "OK" and "Cancel" buttons.</p>
10	Reboot the PC and the modem. After that, the modem is operational.

5 Modem communication

5.1 Verifying modem communication

Connect the modem RS232 port to the PC COM port.

According to the type of modem, configure the DTE RS232 port as follows:

Zelio Logic (SR2 MOD02)	Twido (SR2 MOD03)
<ul style="list-style-type: none"> ▪ Data rate: 115200 bauds, ▪ Data size: 7 bits, ▪ Parity: Even Parity, ▪ Stop bits: 1 Stop bit, ▪ Flow control: hardware flow control activated, ▪ AT commands Echo: Echo deactivated, ▪ DSR Signal: DSR 1, ▪ Ring Register: S0=0 (no automatic answer). 	<ul style="list-style-type: none"> ▪ Data rate: 19200 bauds, ▪ Data size: 8 bits, ▪ Parity: No Parity, ▪ Stop bits: 1 Stop bit, ▪ Flow control: hardware flow control deactivated, ▪ AT commands Echo: Echo deactivated, ▪ DSR Signal: DSR OFF, ▪ Ring Register: S0=2 (answer after 2 rings).

With the Windows HyperTerminal communication application, enter the command **AT(CR)**. The modem should reply with **OK**.

In the case where no communication can be established with the modem:

- Verify the RS232 connection between the DTE and the modem (DCE),
- Verify the configuration of the COM port on the DTE.

Some examples of AT commands which can be sent to the modem once the communication has been established and verified (these commands are explained in detail later in the document):

- **AT+CGSN**: the modem should reply with a 15 digit number (beginning with "353311xxxxxxxx").
- **AT+CPIN=xxxx**: enter the code of the SIM card xxxx (if active).
- **AT+CSQ**: verify the GSM signal reception level.
- **AT+CREG ?**: verify the registration of the modem on the network.
- **ATD<telephone number>**: start a voice call.
- **ATH**: hang-up (end of the call).

5.2 AT commands Echo deactivated

If "no echo" is returned when entering an AT command, it could be that:

- The modem's echo function is deactivated (setting by default).
- The "Local echo" of your communication application is not activated.

The echo is configured by the command **ATE** and requires a back-up with the command **AT&W**.

To activate the modem echo, enter the command **ATE1**.

When using a communication application to send AT commands to the modem, it is recommended to:

- deactivate the "local echo" in your communication application,
- activate the modem echo (enter the command **ATE1**).

For a communication Machine to Machine with the modem, it is recommended to deactivate the modem echo (enter the command **ATE0**) to avoid the CPU receiving redundant responses.

5.3 Verifying GSM receive signal quality

The modem will be able to establish a call only if the received GSM signal is of a sufficient level.

The command **AT+CSQ** will return the reception level (*rssl*) of the signal sent by the closest GSM Base Transceiver Station (*BTS*), as well the receive bit error rate (*ber*).

When the SIM card is present and the PIN code has been entered, the command **AT+CSQ** will return the signal level from the BTS on the subscribed operator network.

When used without the SIM card, this command will simply indicate the closest BTS due to the fact that the modem cannot identify the current subscription. It is therefore advisable to make this test with the SIM card present.

To verify the GSM signal quality, perform the following operations:

Using a communication application, enter the command **AT+CSQ**.

The response is in the following format:

+CSQ: <rssl>,<ber> where: **<rssl>** = indicates the reception level,
<ber> = receive bit error rate.

Verify the value **<rssl>** with the aid of the table below:

<rssl> value	Gain (dbm)	Interpretation	<ber> value	Interpretation
0	-113 dbm	Insufficient	0 to 7	See standard ETSI GSM 05.08
1 to 10	-111 to -95 dbm	Insufficient		
11 to 30	-93 to -53 dbm	Sufficient		
31 (max)	-51 dbm	Perfect		
99		Unknown/not detectable	99	Unknown/not detectable

The GSM modem will function correctly with a minimum **<rssl>** of between 11 and 15.

Below 10 the signal is insufficient, the modem cannot function depending on the geographical situation or the mobility of the vehicle. Above 15 the signal is of a sufficient level.

5.4 Verifying the PIN code

The PIN code is essential in order to make a call or to accept a call from the GSM network.

The PIN code is held on the SIM card and can be modified by the user.

To verify a previously entered PIN code, use a communication application and enter the command **AT+CPIN?**

The table below shows the main responses from the modem:

Command	Response	Interpretation
AT+CPIN?	+CPIN: ERROR	The SIM card is absent or unknown
	+CPIN: READY	The PIN code is correct
	+CPIN: SIM PIN	The PIN code is bad or not yet entered
	+CPIN: SIM PUK	The PUK code is required

5.5 Verifying modem registration on the GSM network

1. Ensure that a valid SIM card is present in the SIM card reader in the modem.
2. Using a communications application, enter the following AT commands:
 - a. **AT+CPIN=xxxx** Enter the PIN code. The user has only 3 attempts to enter the PIN code. After the third attempt, only the PUK code (supplied by the operator) will allow a new PIN code to be entered.
 - b. **AT+CREG?** Verify the network registration status. The response will be of the following format: **+CREG: <mode>,<stat>** where:
 - <Mode>** = un-solicited registration message configuration,
 - <Stat>** = registration status
3. Verify the registration status with the aid of the following table:

Command	Response	Interpretation
AT+CREG?	+CREG: 0,0	The modem is not recognized by the network.
	+CREG: 0,2	The modem is searching for a network operator.
	+CREG: 0,1	The modem is GSM attached to a local operator.
	+CREG: 0,5	The modem is GSM attached to an operator in roaming mode.

If the modem is not registered, verify the antenna connection and the receive signal level (see chapter 5.3).

5.6 Main AT commands (HAYES)

The table below shows at a quick glance the main AT commands useful for the control of the modem.

Description	AT Command	Response	Interpretation
Enter the PIN code	AT+CPIN=xxxx (xxxx = PIN code)	OK	PIN code accepted
		+CME ERROR: 16	PIN code incorrect (1*)
		+CME ERROR: 3	PIN code already entered (1*)
Verification of GSM network registration	AT+CREG?	+CREG: 0,1	The modem is GSM attached to a local operator.
		+CREG: 0,5	The modem is GSM attached to an operator in roaming mode.
		+CREG: 0,2	The modem is searching for a network operator.
		+CREG: 0,0	The modem is not recognized by the network.
Reception of an incoming call (2*)	ATA	OK	Reply to the call
Make a voice call	ATD<telephone number>; (IMPORTANT: the ; at the end of the sequence specifies a voice call)	OK	Communication established
		+CME ERROR: 11	PIN code not entered
		+CME ERROR: 3	The credit has run out or the communication has already been established.
Make an emergency call (112)	ATD112;	OK	Communication established
Lost communication		NO CARRIER	
Hang-up	ATH	OK	

(1*) The command **AT+CMEE=1** allows the display of extended error codes. This command may be saved with the command **AT&W**.

The command **AT+WIND=63** allows the display of the change of status of the SIM card (present, ready...) and to check divers modem states (modem ready after RESET...). This command may be saved with the command **AT&W**.

(2*) The command **AT+CRIC=1** will in the case of an incoming call, display more detailed ring information indicating the type of call - voice, data or fax. This command may be saved with the command **AT&W**.

Examples:

For VOICE: +CRING: VOICE

For DATA: +CRING: REL ASYNC

For FAX: +CRING: FAX

5.7 Powering down the unit

Do not cut off the supply of modem whilst in communication or dialogue without having first detached from the network operator.

To avoid network congestion when powering down the modem, it is essential to first execute the command **AT+CPOF**. If this is not done, then, in certain cases the modem can remain registered on the network.

Before cutting the power in dialog mode (no communication), send the following command to the modem:

AT+CPOF or **AT+CFUN=0** (identical functioning).

The modem will return OK and is no longer registered on the network. The radio module is put into standby and the power may then be removed.

5.8 RS232 (V24) Communication problem

If the modem does not respond to any of the AT commands via the RS232 then refer to the table below for a list of possible causes and solutions.

If the modem...	Check	Action
Returns nothing	Is the modem correctly powered?	Ensure that the modem is connected to an external regulated power source 5.5V to 32V DC (See chapter 6.2.1).
	Is the serial cable connected at both ends (PC and Modem)?	Verify the connection of the serial cable.
	Is the serial cable correctly cabled according to the table in chapter 3.2.1.3?	Cable the serial cable according to the table in chapter 3.2.1.3.
Returns nothing or random characters	Is the communications terminal correctly configured on the PC?	Ensure that the terminal configuration corresponds to that of the modem. See chapter 5.1 for the factory configuration according to the modems.
	Is there another application using the same port thus creating a conflict?	Close the conflicting application.
	Is the modem echo deactivated and without message reporting?	Enter the command ATE1Q0 followed by AT&W if a backup is required.

5.9 "ERROR" message

The modem returns the message "**ERROR**" (in response to an AT command) in the following cases:

- The COM port is not directed to the modem but to another modem. Enter the command **ATI**. The response should be **WAVECOM MODEM....** All other responses indicate a dialog with another modem. Verify the COM port used in the communications application.
- The syntax of the AT command is incorrect. Re-enter the command.
- The syntax of the AT command is correct, but with incorrect parameters:
 - Enter the command **AT+CMEE=1** to obtain an error message with its error code instead of a simple "ERROR" message,
 - Enter again the AT command which previously caused a problem to obtain the error code. In the case of an error, the response is in the form:

+CME ERROR: <error code> or +CMS ERROR: <error code>

Note: It is strongly recommended to systematically allow the modem to return error codes (enter the command **AT+CMEE=1**).

5.10 "NO CARRIER" message

If the modem returns the message "NO CARRIER" after an attempted call (voice or data), check the table below for a list of possible causes and solutions.

Modem returns...	Check	Action
"NO CARRIER"	Is the received GSM signal strong enough?	Verify the received signal quality (see chapter 5.3).
	Is the modem registered on the network?	Verify network registration (see chapter 5.5).
	Is the antenna correctly connected?	Check the GSM antenna installation.
"NO CARRIER" (when attempting a VOICE call)	Has the semi-colon (;) been entered immediately after the telephone number in the AT command?	Ensure that the semi-colon (;) been entered immediately after the telephone number in the AT command, for example: ATD0123456789;
"NO CARRIER" (when attempting a DATA call)	Has the SIM card been configured for data / fax calls?	Ensure that the SIM card is allowed to make data / fax calls (check with your SIM card supplier).
	Is the selected modulation type supported by the called number?	Ensure that the selected modulation type is supported by the called number.
	Is the selected modulation type supported by the network?	Ensure that the selected modulation type is supported by the network. If not, select a compatible modulation type with the command AT+CBST=0,0,1 .

If the modem returns the message "NO CARRIER", use the command **AT+CEER** to see the extended error code.

Refer to the table below for a list of extended error codes and their meanings.

Error code	Meaning	Observations
1	Unassigned (unallocated) number	
16	Normal call clearing	
17	User busy	
18	No user responding	
19	User alerting, no answer	
21	Call rejected	
22	Number changed	
31	Normal, unspecified	
50	Requested facility not subscribed	Check your subscription (data subscription available?).
68	ACM equal to or greater than ACMmax	No more SIM card credit or card expired.
252	Call barring on outgoing calls	
253	Call barring on incoming calls	
3, 6, 8, 29, 34, 38, 41, 42, 43, 44, 47, 49, 57, 58, 63, 65, 69, 70, 79, 254	Network cause	Check with the operator.

6 Functional Description

6.1 Architecture

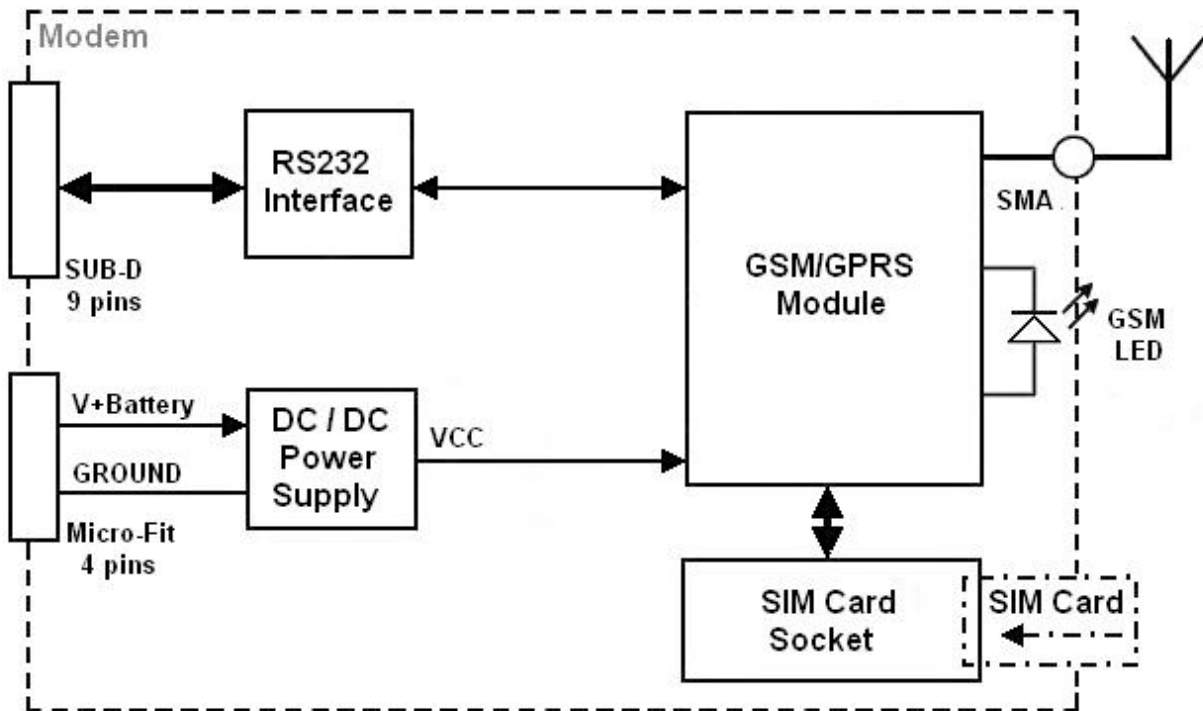

6.2 Power Supply

6.2.1 General

The modem must be powered (V+BATTERY) by an external regulated DC power supply of in Safety Extra Low Voltage (SELV) between +5.5 V and +32 V.

The modem's various internal DC voltages are provided by an internal DC/DC converter.

If the input voltage (V+BATTERY) falls below 5.5 V, the modem will not operate correctly.

6.2.2 Protections

The modem is protected by an in-line 2.5 A / 250 V fast blow fuse in the power supply cable supplied with the modem.

It also has internal protection against power supply spikes of more than 32 V.

Filter specifications:

- Input/output EMI/RFI protection,
- Signal smoothing.

6.3 RS232 serial link

6.3.1 General

The RS232 interface provides a level translation between the Wavecom GSM/GPRS Module (DCE) and the PC COM port (DTE).

The RS232 interface is protected internally (ESD protection) against external electrostatic spikes.

Filter specifications:

- Input/output EMI/RFI protection,
- Signal smoothing.

The following signals are available:

- TX data (CT103/TX)
- RX data (CT104/RX)
- Request To Send (CT105/RTS)
- Clear To Send (CT106/CTS)
- Data Terminal Ready (CT108-2/DTR)
- Data Set Ready (CT107/DSR)
- Data Carrier Detect (CT109/DCD)
- Ring Indicator (CT125/RI)

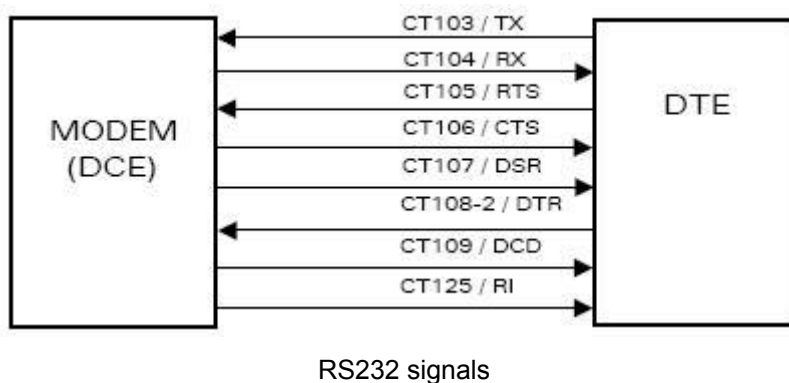

The RS232 interface allows a certain amount of flexibility in the use of its signals. For example, the modem may operate in the 3-wire mode using only the TX, RX and GND signals. However, the CTS and RTS signals will also be required for GPRS applications and X-Modem upgrade.

6.3.2 Mode Autobauding

The auto-baud mode allows the modem to automatically detect the transmission speed used by the DTE. Only the following speeds will be detected: 2400, 4800, 9600, 19200, 38400, 57600 bps. Auto-baud detection cannot be guaranteed for speeds below or above these speeds.

The auto-baud mode is controlled by the AT commands.

Note: See at chapter 5.1 for the default configuration of modems.

6.3.3 Pins description

Table: Pins description

Signal	Pin number on Sub-D connector	I/O	RS232 standard	Description
CTXD/CT103	2	I	TX	Transmit serial data
CRXD/CT104	3	O	RX	Receive serial data
CRTS/CT105	7	I	RTS	Request To Send
CCTS/CT106	8	O	CTS	Clear To Send
CDSR/CT107	6	O	DSR	Data Set Ready
CDTR/CT108-2	4	I	DTR	Data Terminal Ready
CDCD/CT109	1	O	DCD	Data Carrier Detect
CRI/CT125	9	O	RI	Ring Indicator
CT102/GND	5			Ground

7 Technical Characteristics

7.1 Mechanical

Table: Mechanical characteristics

Dimensions	73 x 54.5 x 25.5 mm (excluding connectors)
Overall Dimensions	90 x 54.5 x 25.5 mm
Weight	≈ 88 g max. (modem only) < 335 g max. (modem + accessories)
Volume	101.5 cm ³
Case	Extruded aluminum
Ingress Protection	IP31

The illustration below indicates the dimensions (in mm) of the modem showing the clearances necessary for installation.

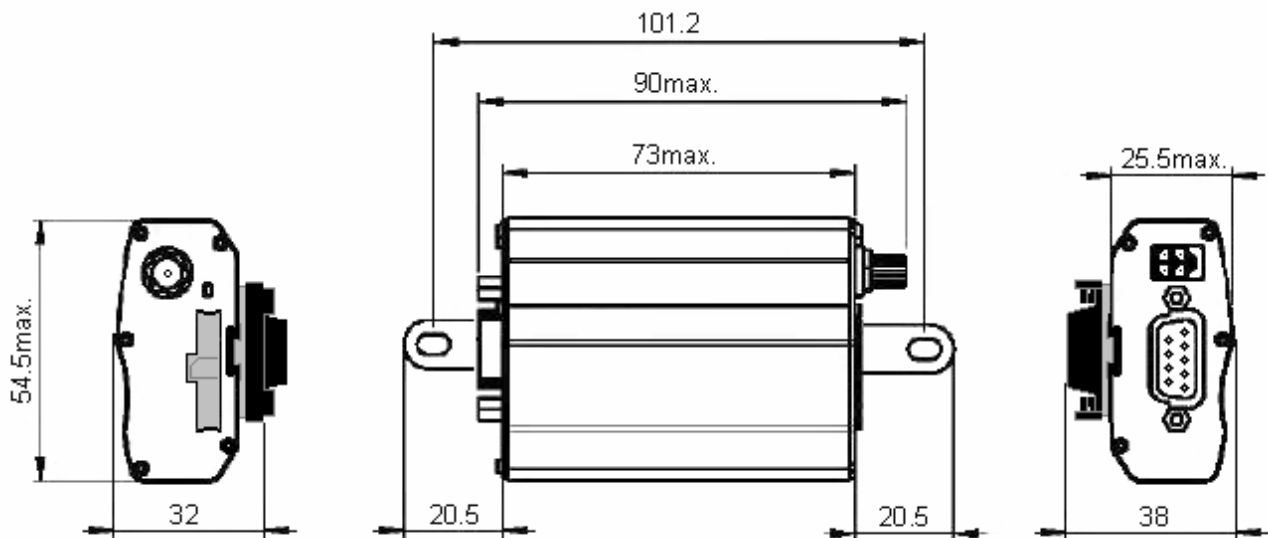

7.2 Electrical

7.2.1 Power supply

Table: Voltage range and power consumptions

Operating voltage range	▪ 5.5 V to 32 V DC
-------------------------	--------------------

Note: The modem is permanently powered once the power supply is connected.

The table below indicates the consequences of over and under-voltages to the modem.

Table: Effects of a power supply level below 5.5 VDC or above 32 VDC.

If the voltage:	Then:
▪ Falls below 5.5 V	▪ GSM communication may not operate properly.
▪ Goes above 32 V (transient peaks)	▪ The modem has built in protection.
▪ Goes above 32 V (continuous over-voltage)	▪ The modem is then protected by the in-line fuse. (The modem is short-circuited by an internal varistor).

The table below indicates the power supply consumption of the modem without the RS232 connected.

Table: Consumption (1*) without RS232 connected

CONDITIONS T = 25°C and 3 V SIM card		850/900 MHz		1800/1900 MHz	
		I Nom.(mA)	I Max.(mA)	I Nom.(mA)	I Max.(mA)
Idle mode (2*)	at 5.5V	17.5	23	17.5	23
	at 12V	11.7	16.5	11.7	16.5
	at 24V	10	14	10	14
	at 32V	8.6	11.5	8.6	11.5
Idle mode 32K (3*)	at 5.5V	12	14.5	12	14.5
	at 12V	9.2	11.3	9.2	11.3
	at 24V	8	10.5	8	10.5
	at 32V	7.7	9.7	7.7	9.7
In communication GSM 1RX/1TX	at 5.5V	182.5	195.5	135	145
	at 12V	96	103.5	71.75	78
	at 24V	50	54	37	40
Power (2W/1W)	at 32V	40	44.5	31	34.75
In communication GPRS CL10 3RX/2TX	at 5.5V	320	341	230	242
	at 12V	165	177	120	127.5
	at 24V	87	93	64	68
Power (2W/1W)	at 32V	67	72	50	53.5
During TX bursts	at 5.5V	1178	1400	670	780
	at 12V	600	712	342	400
	at 24V	320	375	180	220
Power (2W/1W)	at 32V	230	274	132	156

(1*) The power consumption may vary by 5% over the whole operating temperature range (-20 °C to +55 °C)

(2*) Idle mode: modem is registered on the network but not in communication.

(3*) Idle mode 32K: low power mode controlled by an external application, via the DTR CTS signals.

7.2.2 Interface SIM

Table: SIM card characteristics

SIM Card	3 V or 1.8 V
----------	--------------

7.2.3 GSM/DCS

7.2.3.1 Frequency bands

Table: Frequency ranges

Parameter	GSM 850	E-GSM 900	DCS 1800	PCS 1900
Transmission Frequency	824 to 849 MHz	880 to 915 MHz	1710 to 1785 MHz	1850 to 1910 MHz
Reception Frequency	869 to 894 MHz	925 to 960 MHz	1805 to 1880 MHz	1930 to 1990 MHz

7.2.3.2 RF Performances

The RF performances are compliant with the ETSI GSM 05.05 recommendation.

The RF performances for receiver and transmitter are given in the table below.

Table: Receiver and Transmitter RF performances

Receiver	
E-GSM900/GSM850 Reference Sensitivity	- 104 dBm
DCS1800/PCS1900 Reference Sensitivity	- 102 dBm
Selectivity at 200 kHz	> +9 dBc
Selectivity at 400 kHz	> +41 dBc
Linear dynamic range	63 dB
Co-channel rejection	>= 9 dBc
Transmitter	
Maximum output power (E-GSM900/GSM850) at ambient temperature	33 dBm +/- 2 dB
Maximum output power (DCS1800/PCS1900) at ambient temperature	30 dBm +/- 2 dB
Minimum output power (E-GSM900/GSM850) at ambient temperature	5 dBm +/- 5 dB
Minimum output power (DCS1800/PCS1900) at ambient temperature	0 dBm +/- 5 dB

7 Technical Characteristics

7.2.3.3 External GSM Antenna

The external GSM antenna is connected to the modem via the SMA/M connector. It must have the characteristics listed in the table below.

Table: External GSM antenna characteristics

Antenna frequency range	Quad-bands 850/900/1800/1900 MHz
Impedance	50 Ohms nominal
DC Impedance	0 Ohm
Gain (antenna + cable)	0 dBi (in a minimum direction)
VSWR (Rx max TX max)	1.5:1
Polarization	Linear

Note: See chapter 3.2.2.2, for GSM antenna recommended by Schneider Electric.

7.3 Environmental characteristics

For the correct operation of the modem, stay within the limits listed in the table below.

Table: Environmental characteristics

Operating temperature	-20 °C to +55 °C
Storage temperature	-40 °C to +70 °C
Operating humidity without condensation	HR < 95% at +55°C
Atmospheric pressure	normal

7.4 Standards / Conformities

The product conforms to the following requirements:

- R&TTE 1999/5/EC Directive,
- Regulations of standard ETSI EN 301 489-7, EN301 419-1 et EN 301 511,
- 2002/96/CE DEEE (crossed out wheelie bin).

The Modem conforms to the 2002/95/CE – ROHS requirements.

Conformity available on web-site www.telemecanique.com.

7.5 Protections

7.5.1 Power supply

The modem is protected by an in-line fuse in the power supply cable supplied with the modem.

The fuse type is: FSD 2.5 A / 250 V FAST.

7.5.2 Over-voltage

The modem is protected against voltages over +32 VDC.

When the supply voltage exceeds +32 VDC, the power supply is cut in order to protect the internal electronic components against the over-voltage.

7.5.3 ESD

The modem will withstand ESD's on all accessible parts of the modem (except for the RF part) according to the IEC 61000-4-2 requirements:

8 kV air discharge,

4 kV contact discharge.

7.5.4 Miscellaneous

Filter specifications:

Input/output EMI/RFI protection,

Signal smoothing.

8 Security Recommendations

8.1 General

It is important to follow the specific regulations for the use of radio operator equipment, in particular the possible risks of radio frequency interference (RFI). Please follow carefully the security advice given below.

Turn off your GSM modem:

- On an aircraft. The use of cellular telephones can endanger the operations of the plane, disturb the cellular network and is illegal. The non-observance of this instruction can lead to the suspension of cellular telephone services as well as a fine.
- At a refueling station.
- In any area with a potentially explosive atmosphere which could lead to an explosion or a fire.
- In hospitals and similar places where medical equipment may be in use.

Restrictions of use of radio operator equipment in:

- Fuel depots.
- Chemical factories.
- Locations where demolition is under way.
- Other places where signs indicate that the use of cellular telephones is prohibited or dangerous.
- Other places where you should normally turn off the engine of your vehicle.

There can be a hazard associated with the use of your GSM modem close to insufficiently protected medical devices such as acoustic apparatus and pacemakers. Consult the manufacturers of medical equipment to determine if it is adequately protected.

The use of your GSM modem close to other electronic equipment may also cause interference if the equipment is insufficiently protected. Observe all the manufacturer's warnings and recommendations for the equipment.

The modem is designed to be used with "fixed" and "mobile" applications:

- "Fixed application": The GSM modem is physically connected to a site and it is not possible to be easily moved to another site.
- "Mobile application": The GSM modem is designed to be used in various places (other than fixed) and is intended for use in portable applications.

8.2 Security in a vehicle

Do not use your GSM modem whilst driving a vehicle, unless equipped with a correctly installed ear-piece/hands-free kit.

Respect the national regulations for the use of cellular telephones in vehicles. Road safety is always a priority.

An incorrect installation of a GSM modem in a vehicle could cause incorrect operation of the electronics of the vehicle. To avoid such problems, ensure that the installation is carried out by a qualified person. At the time of the installation, verify the electronic protection system of the vehicle.

The use of an apparatus to activate the headlights or the horn of a vehicle on a public highway is not authorized.

8.3 Care and maintenance

The suggestions below will help you to look after and preserve this product for many years.

- Do not expose the modem to the extreme environments such as a high temperature or a high humidity content.
- Do not use or store the modem in dusty or dirty places.
- Do not open or disassemble the modem. ALL WARRANTIES ARE VOID IF THE PRODUCT IS OPENED, ALTERED, AND/OR DAMAGED.
- Do not expose the modem to liquids. It is not impermeable.
- Avoid dropping, striking, or shaking the modem violently.
- Do not place the modem near computer disks, credit or voyage cards or other magnetic media. The information contained on the discs or the cards can be affected by the modem.
- The use of third party equipment or accessories, not made or authorized by Schneider Electric can cancel the guarantee.

8.4 Your responsibility

This modem is under your responsibility. Treat it with care. It is not a toy. Install it in a secure place out of the reach of children.

Make a careful note of your PIN and PUK SIM Card codes. Familiarize yourself with the modem and its functions. Use the security functions to prevent unauthorized use and/or theft.